















**!D**

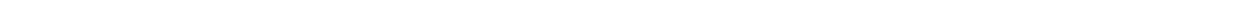









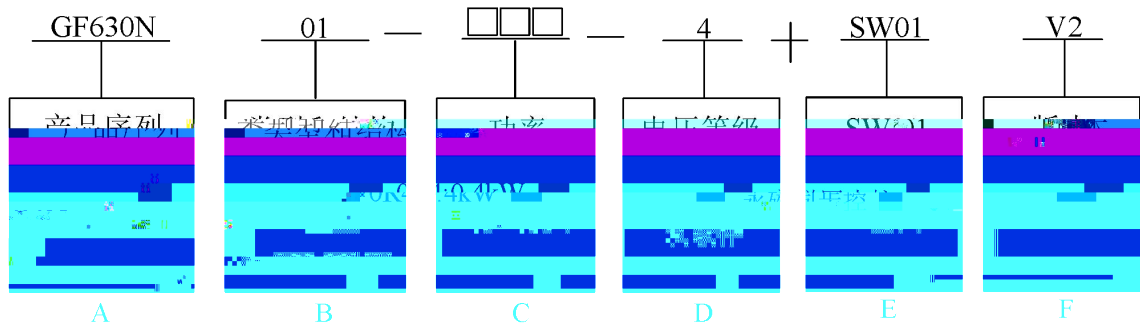

---

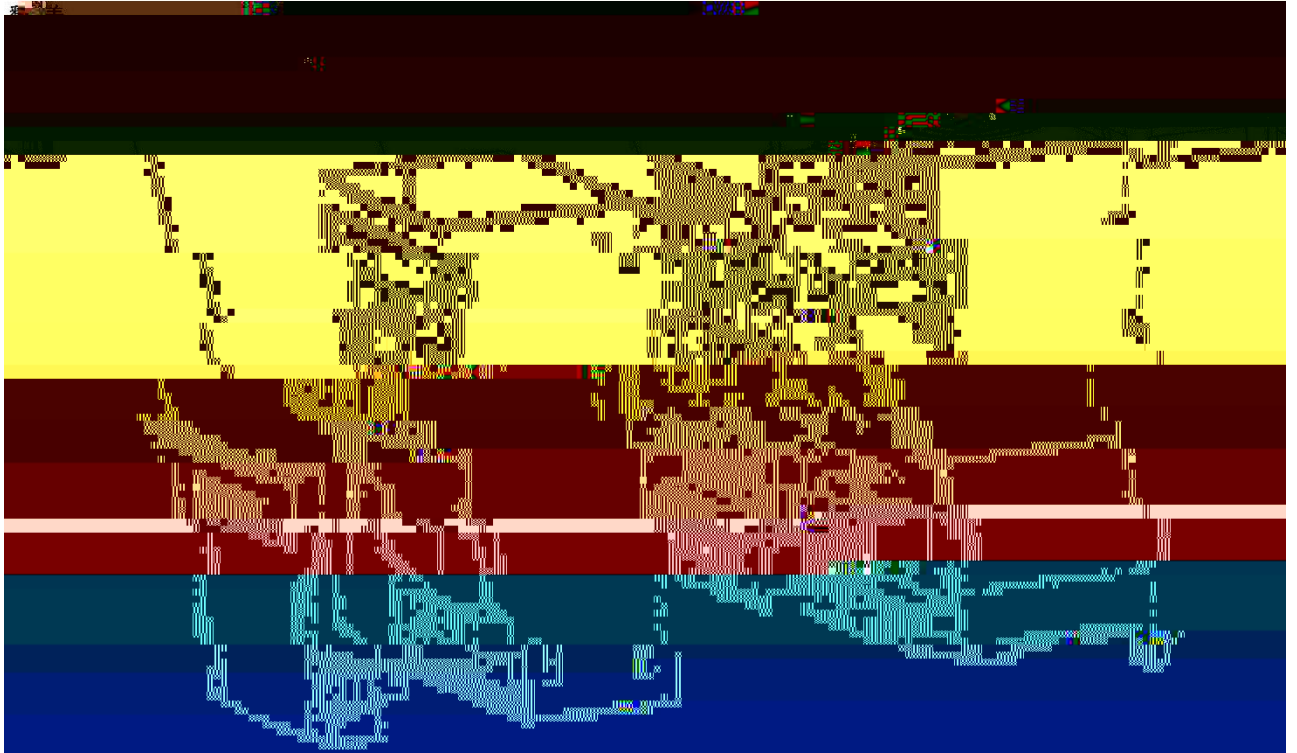

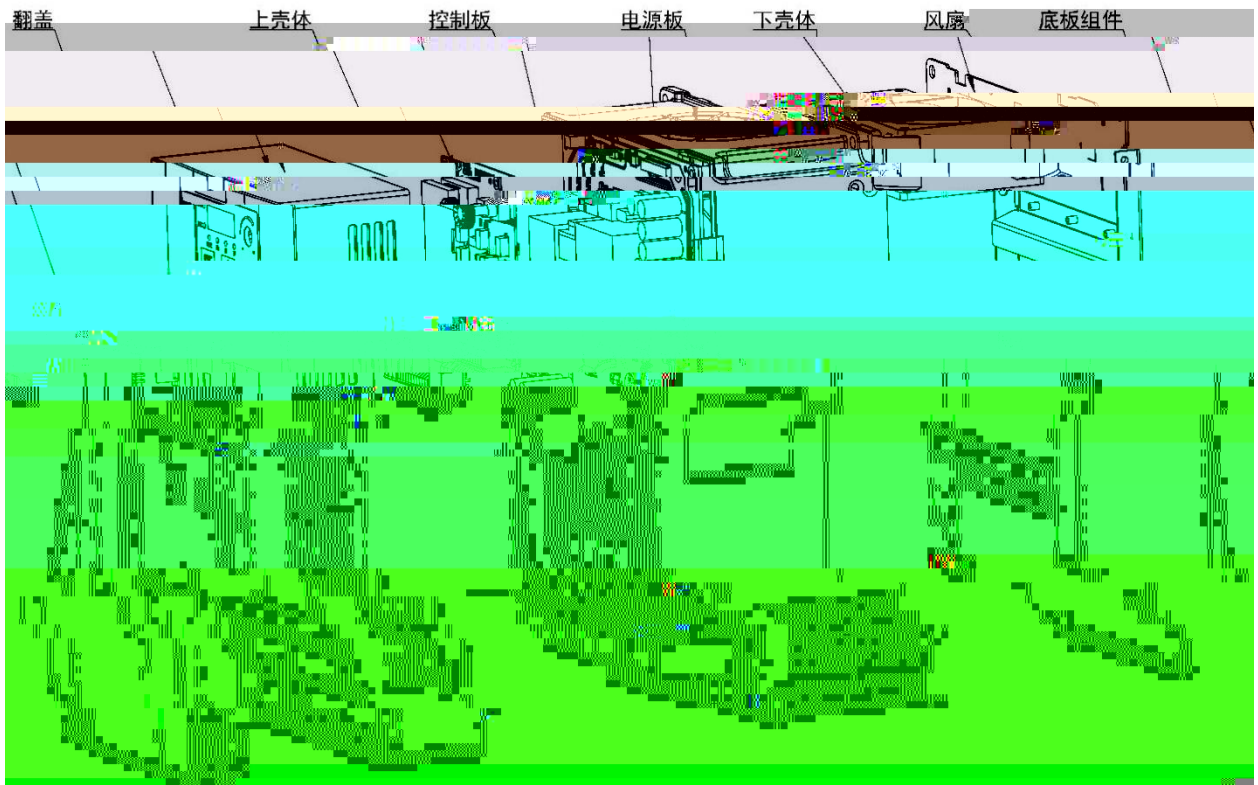

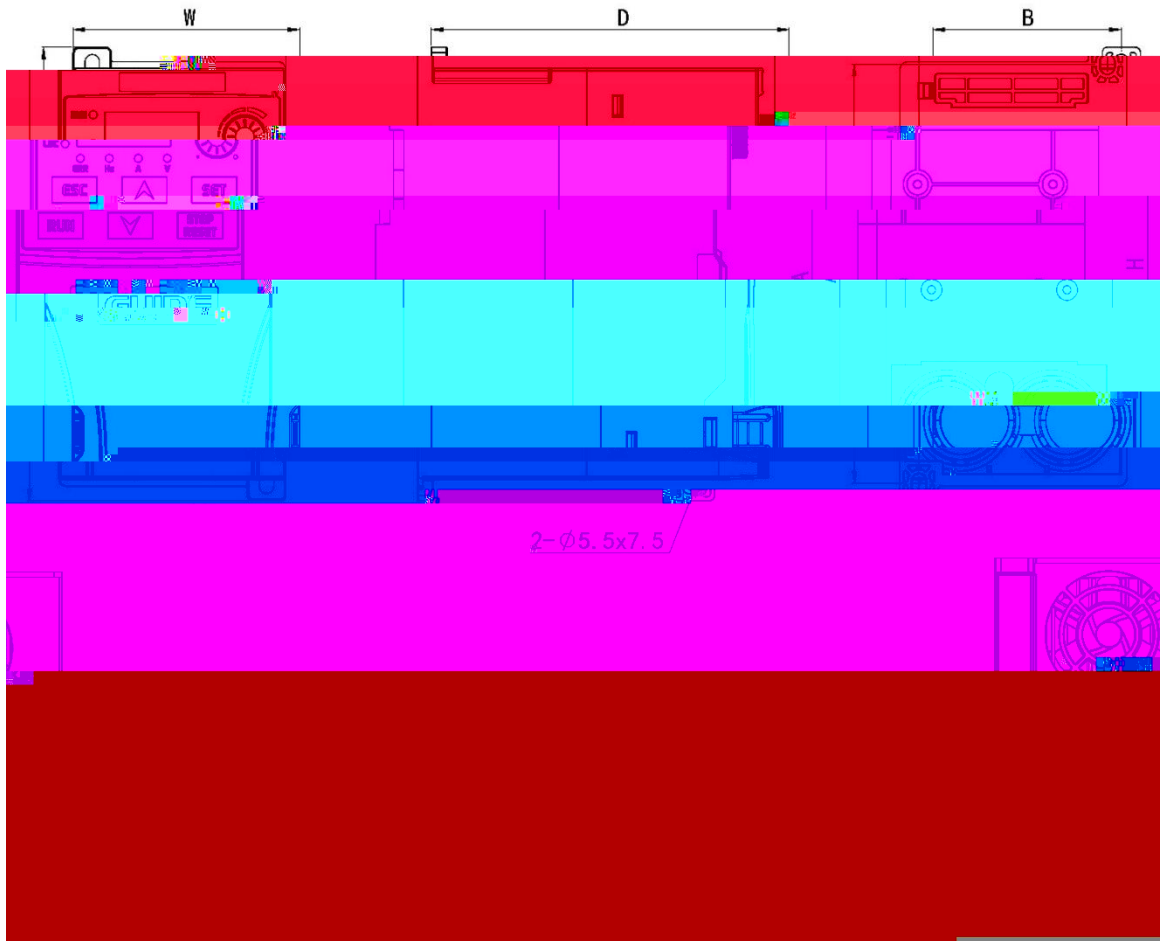

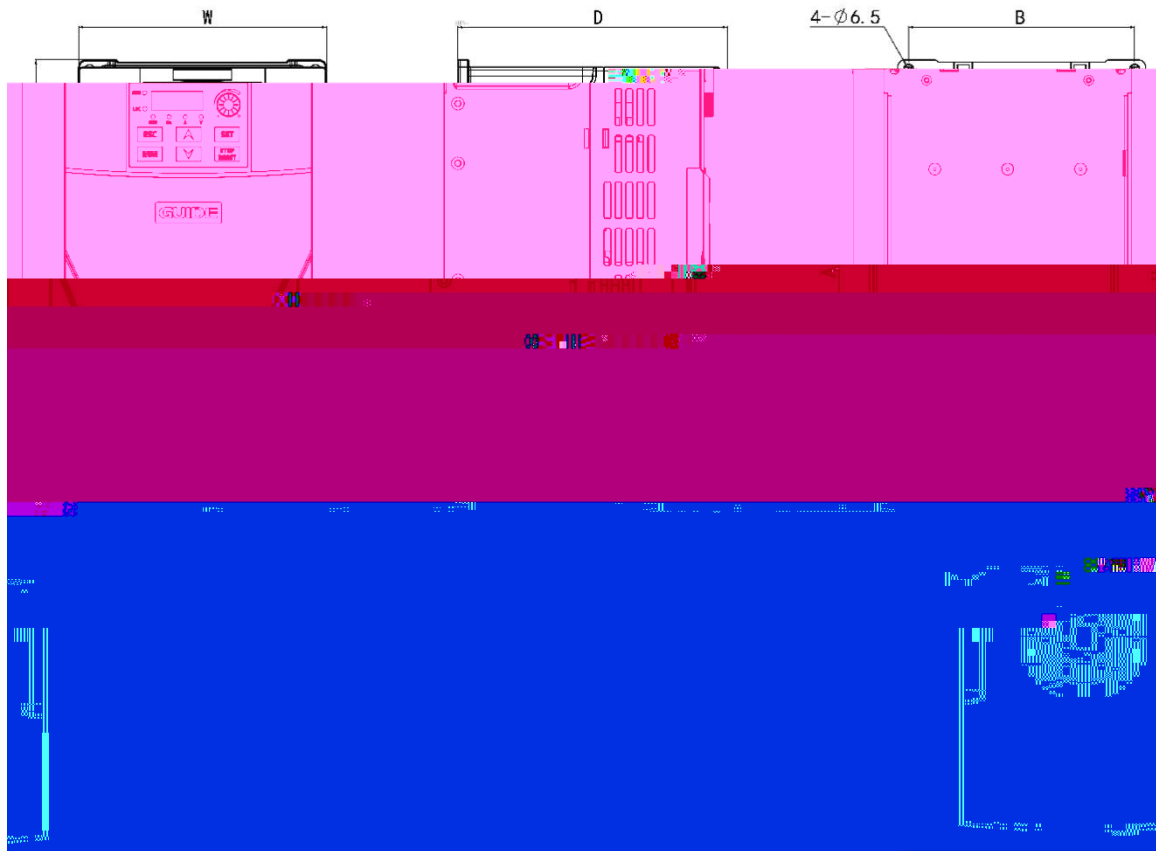







AC380V



GF630N01系列变频器

断路器



熔断器



接触器









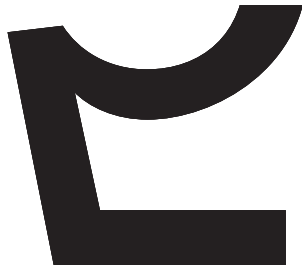

---

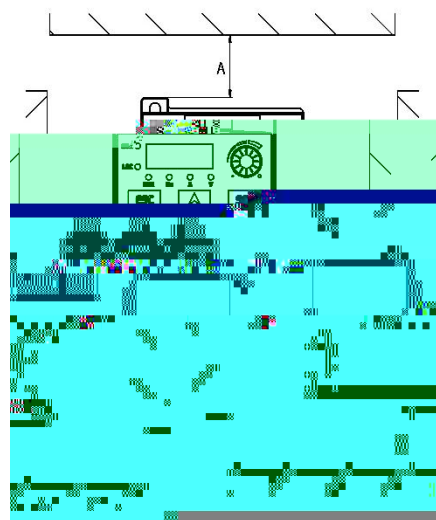
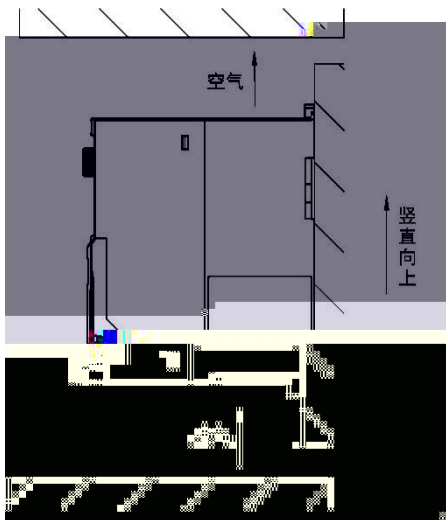
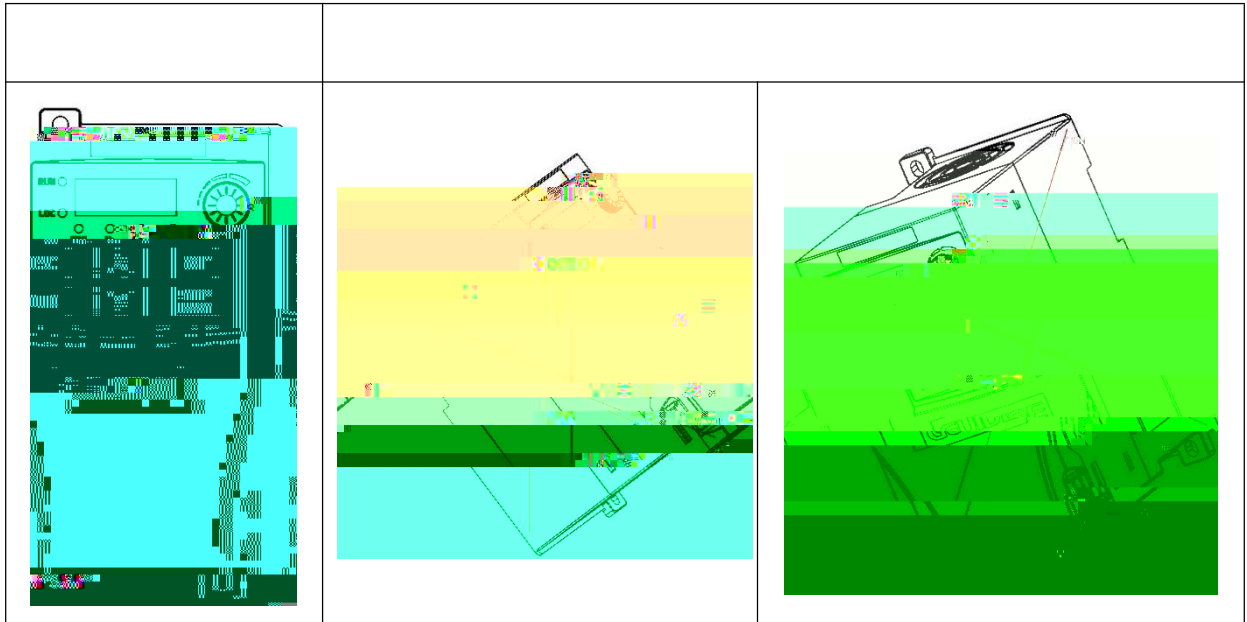

---



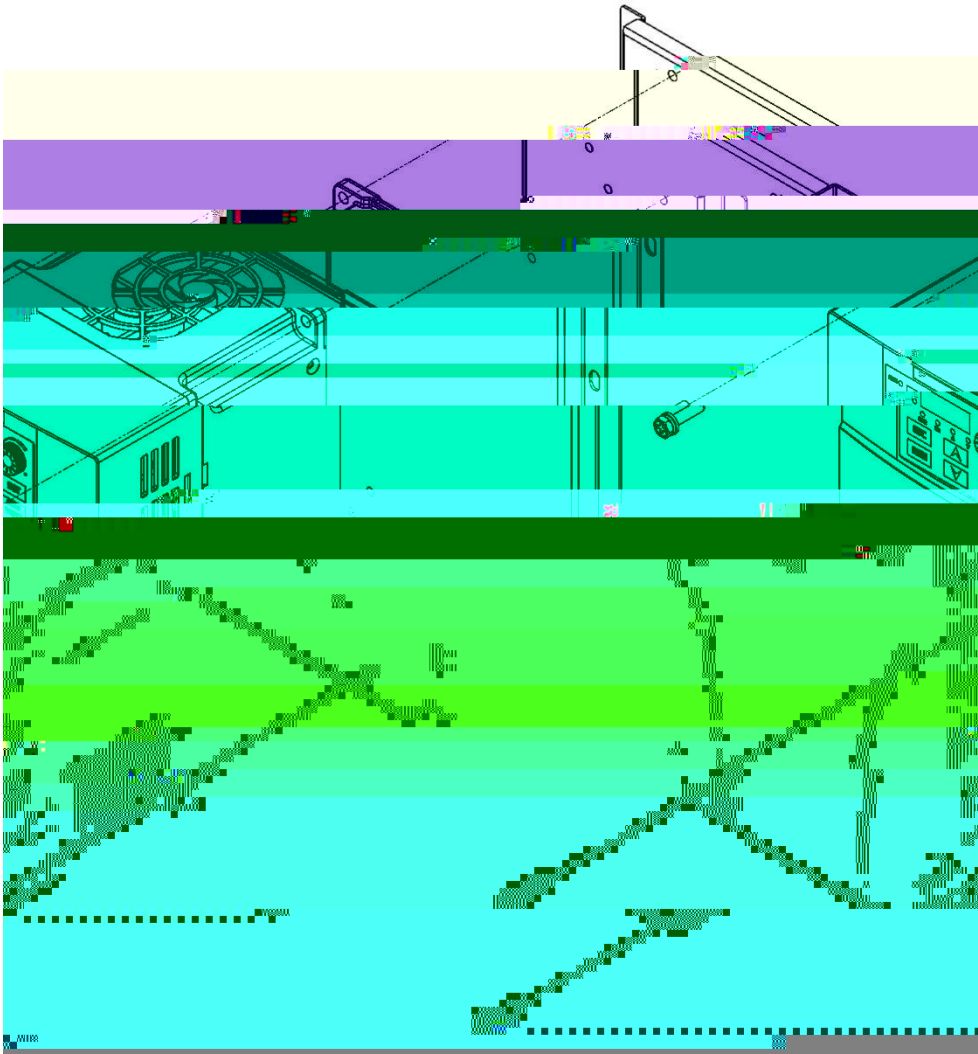

---

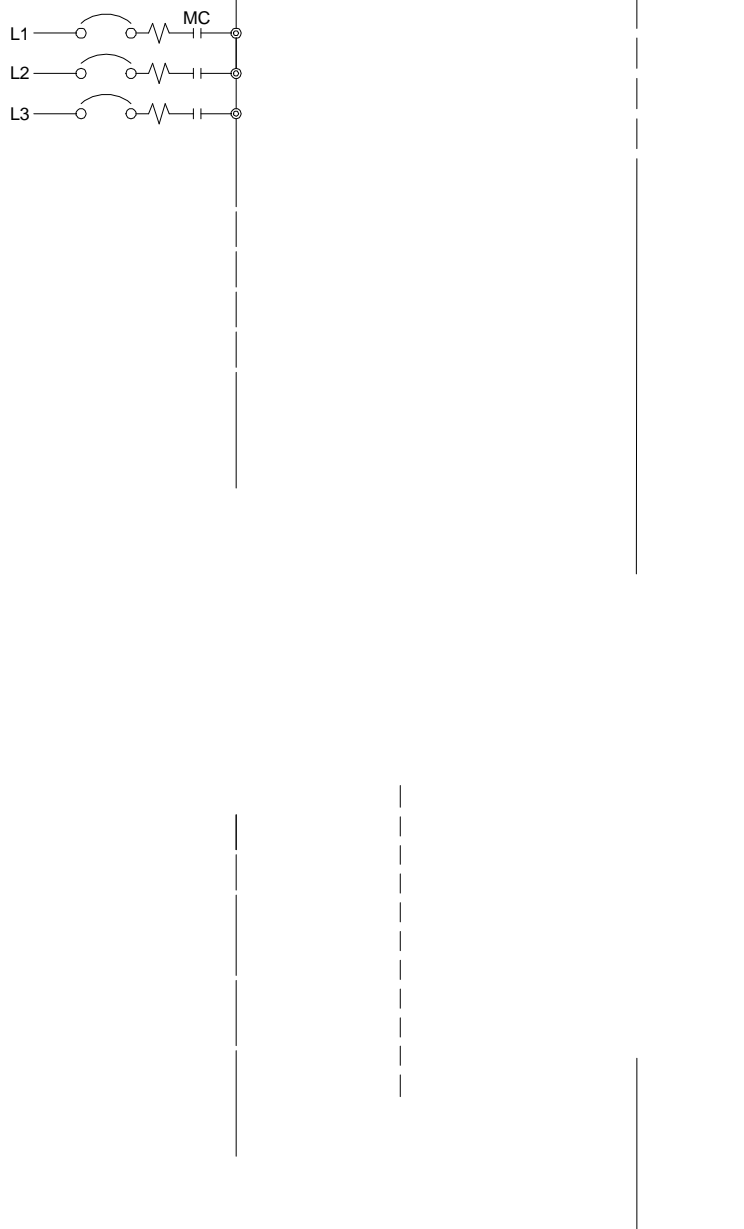

---

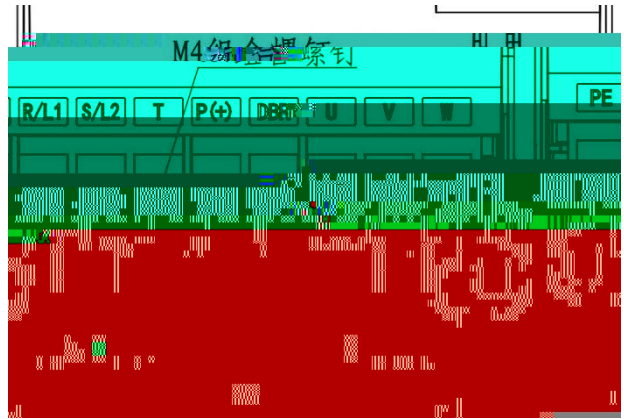
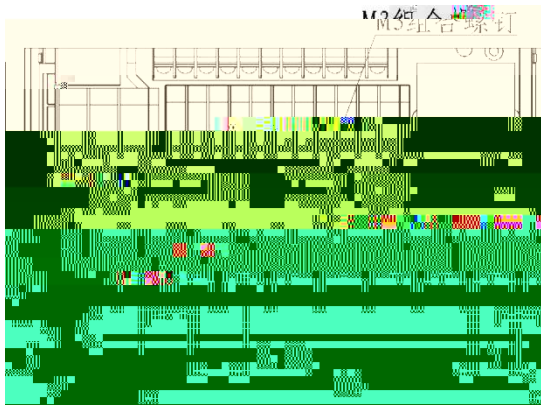



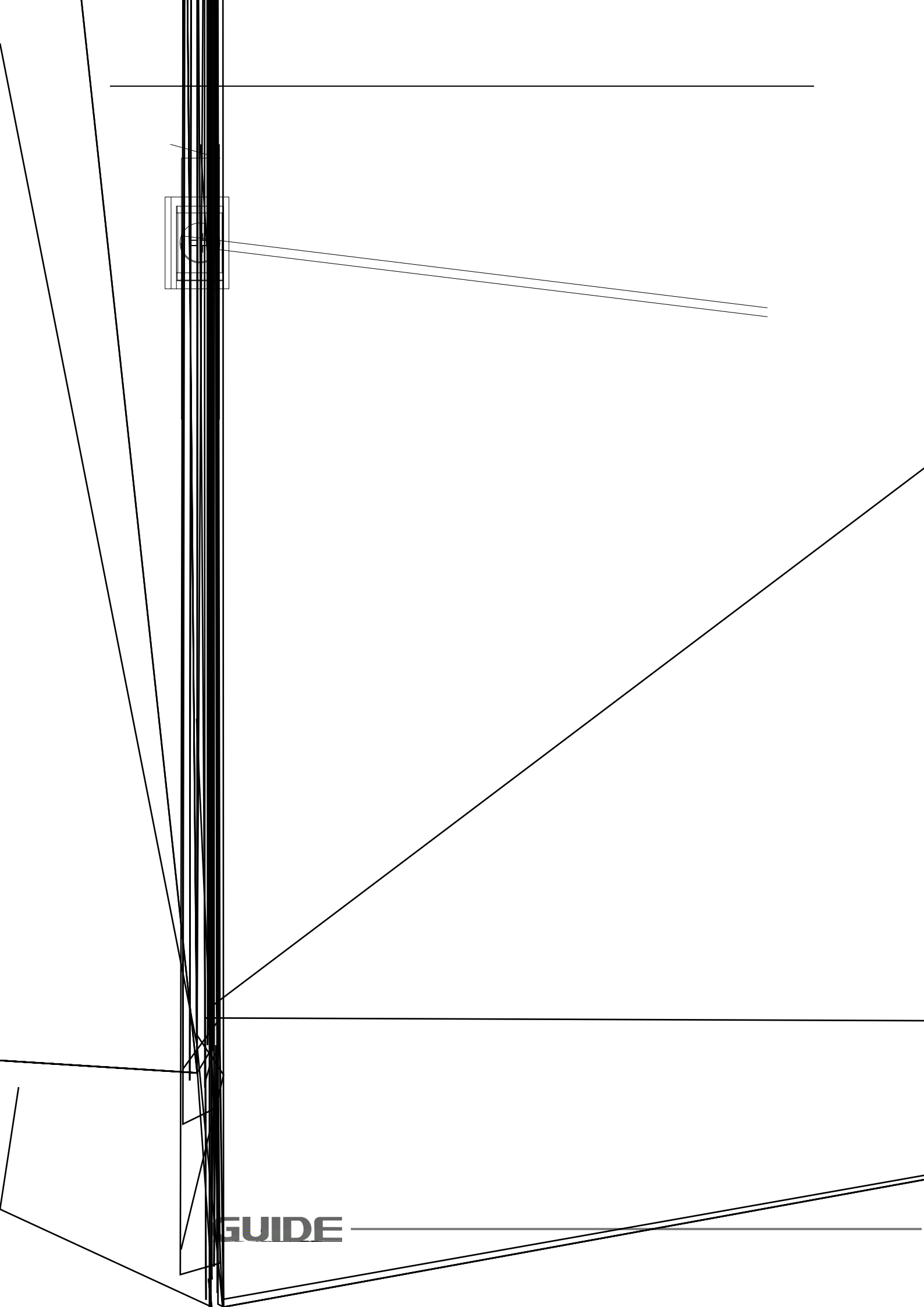



**GUIDE**

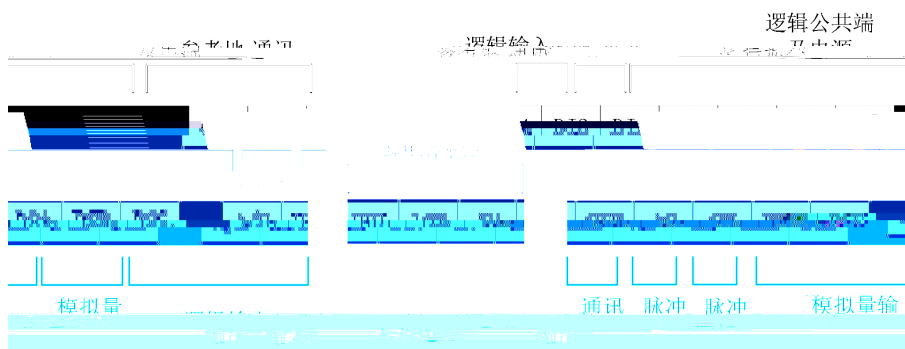
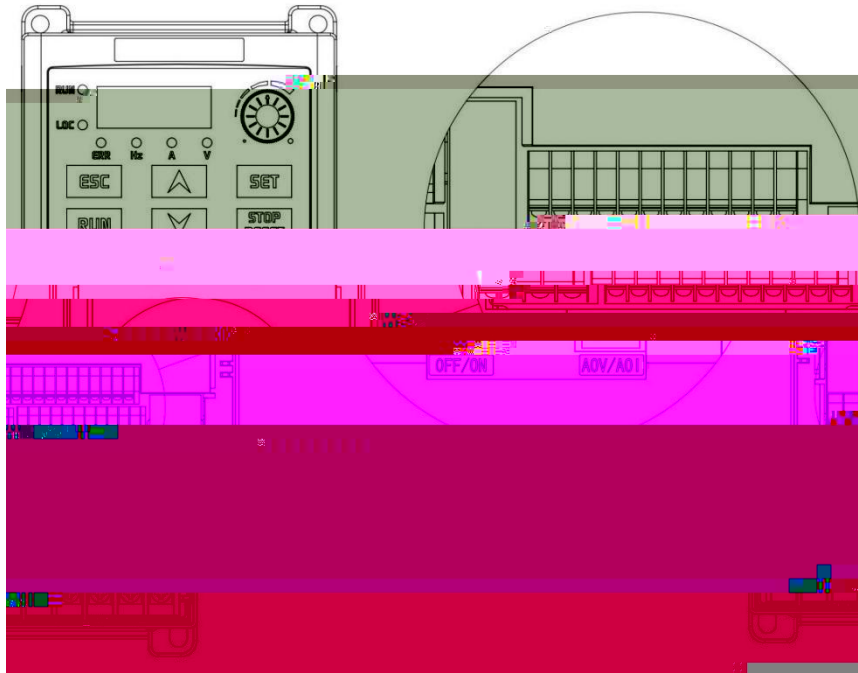







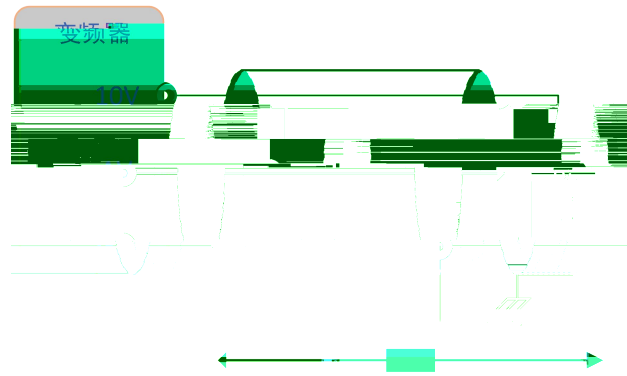
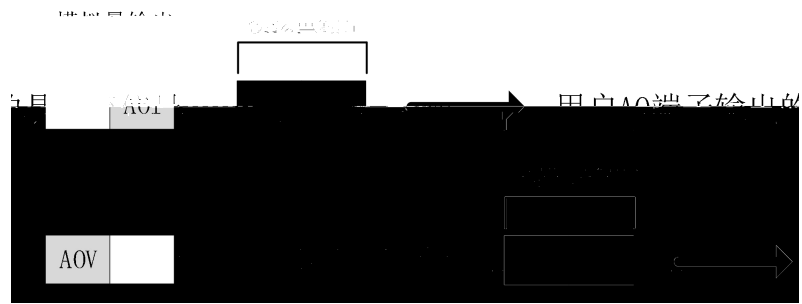

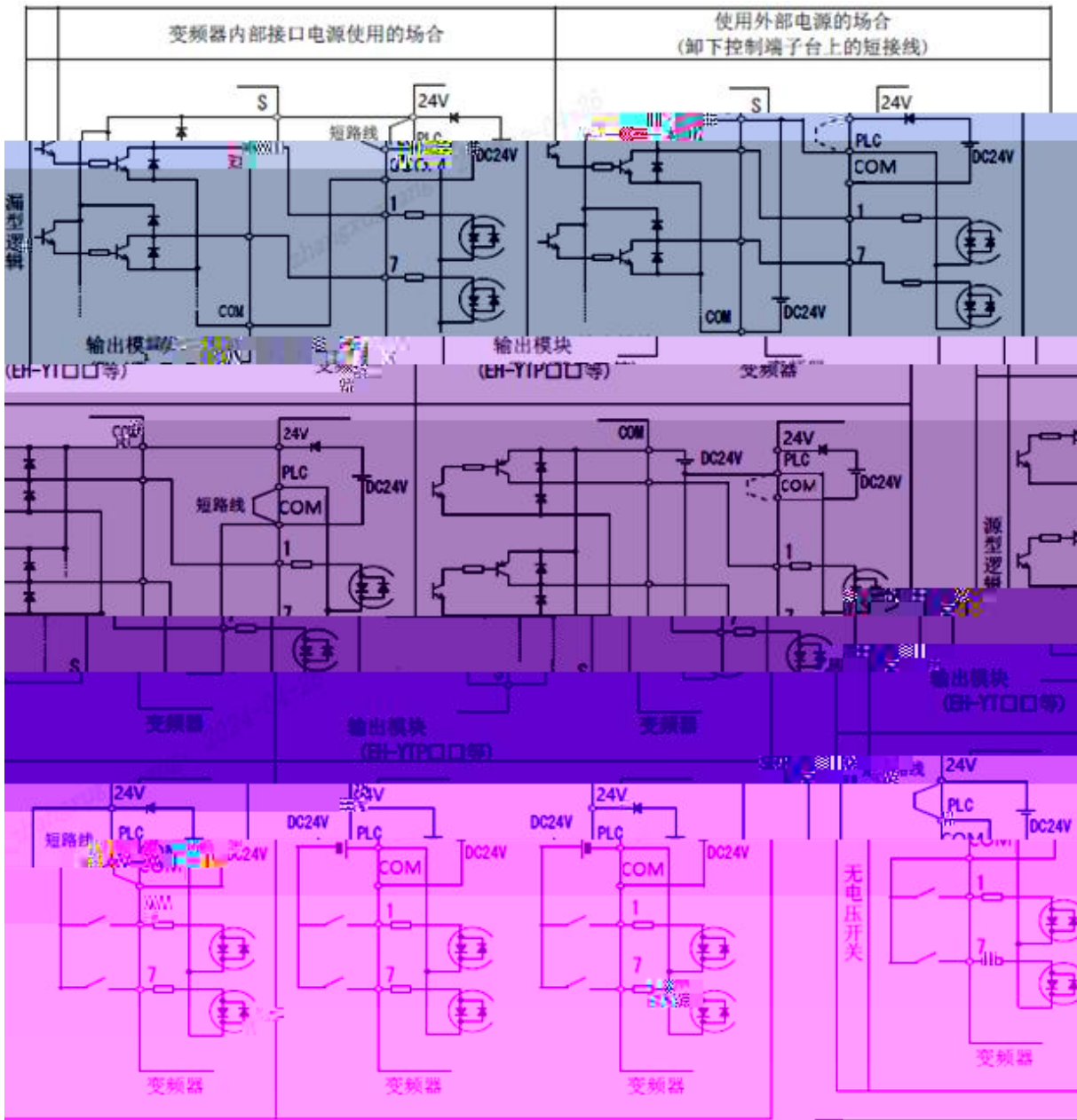
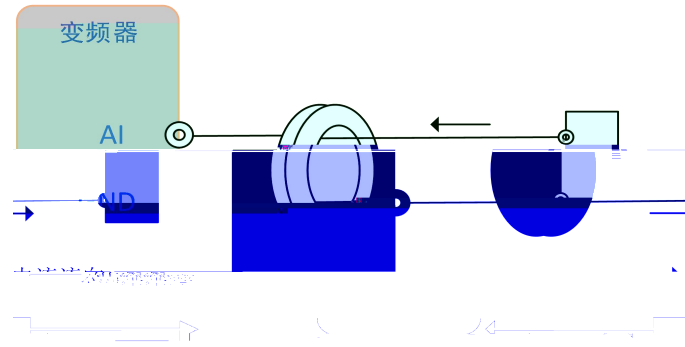

Q Q V C C V



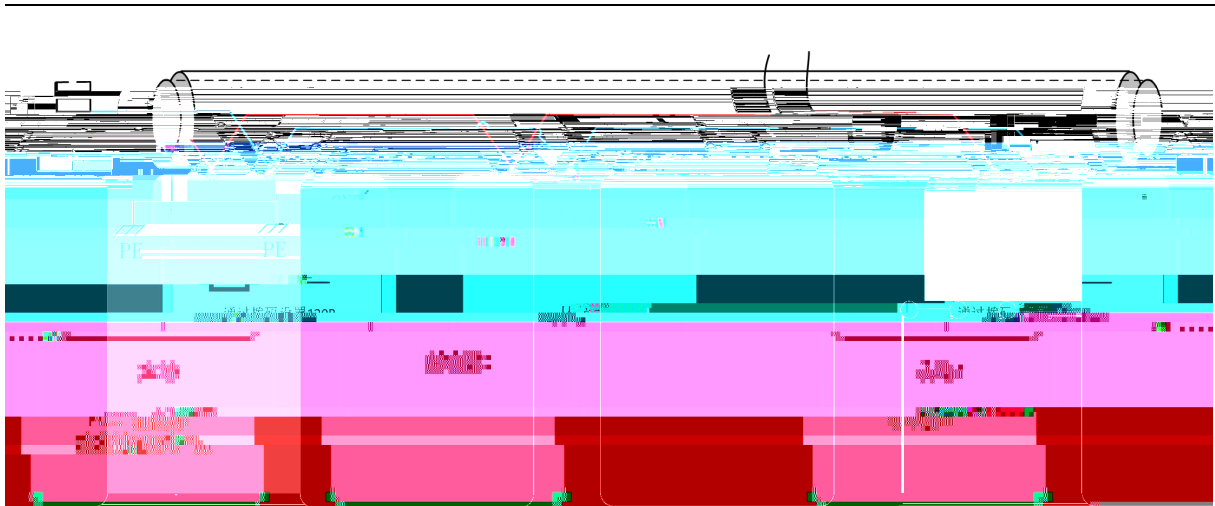

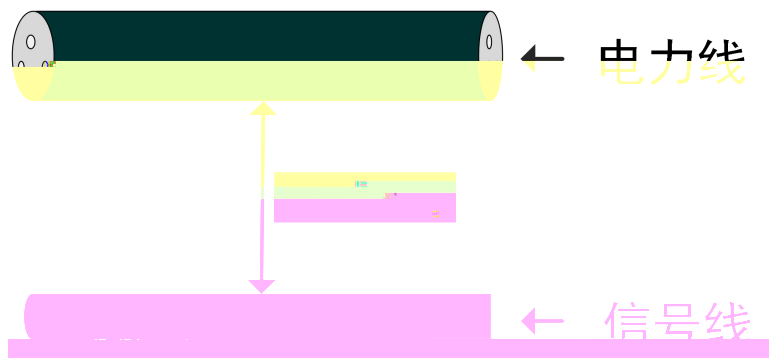



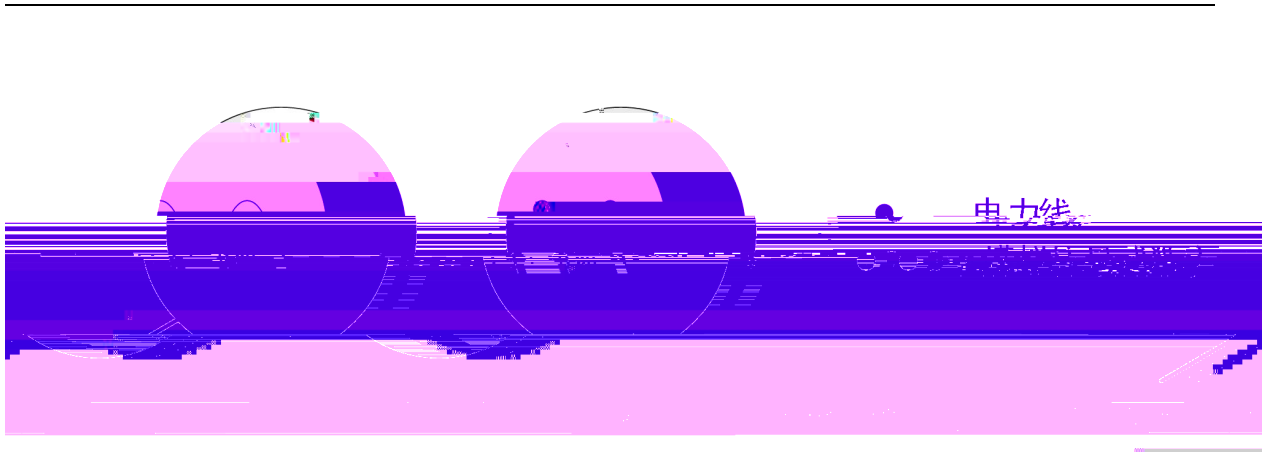

IO

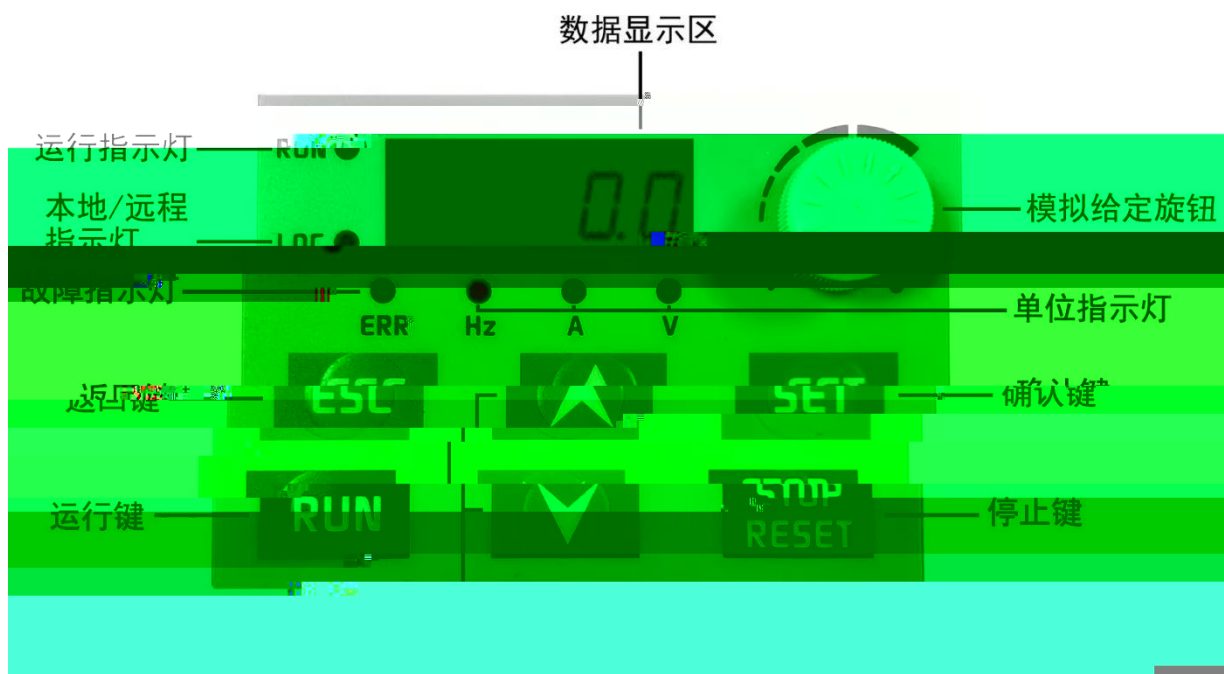







		
		
		
		
		

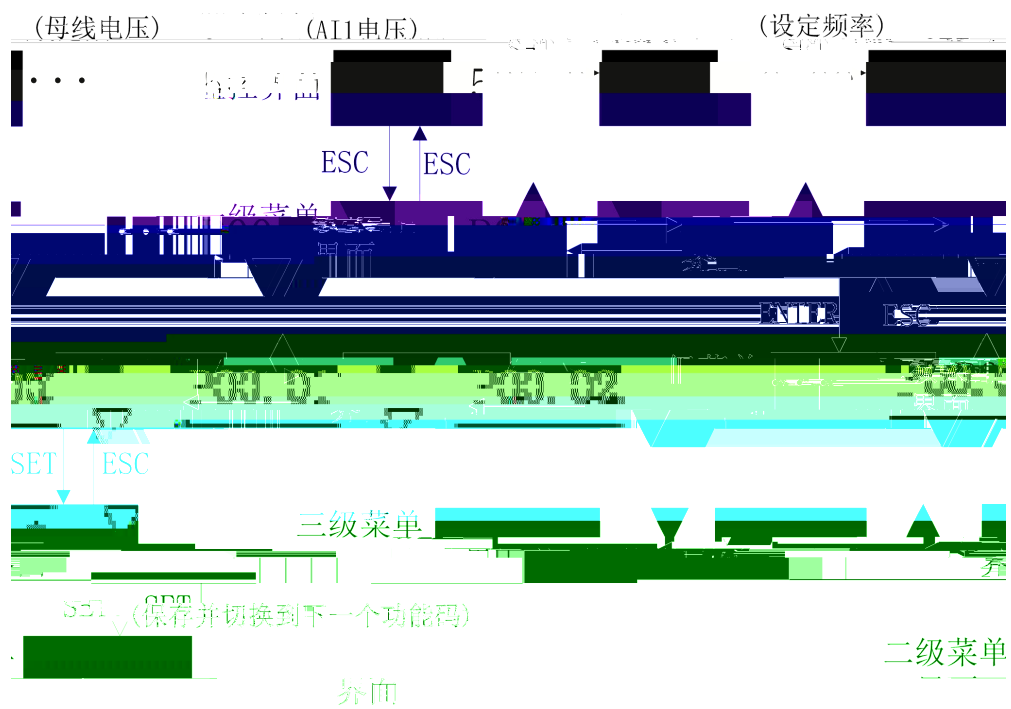





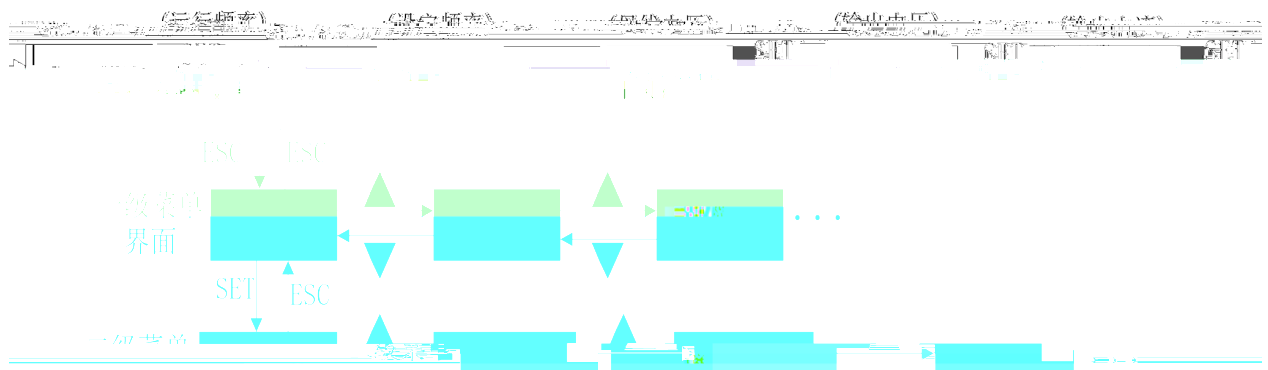

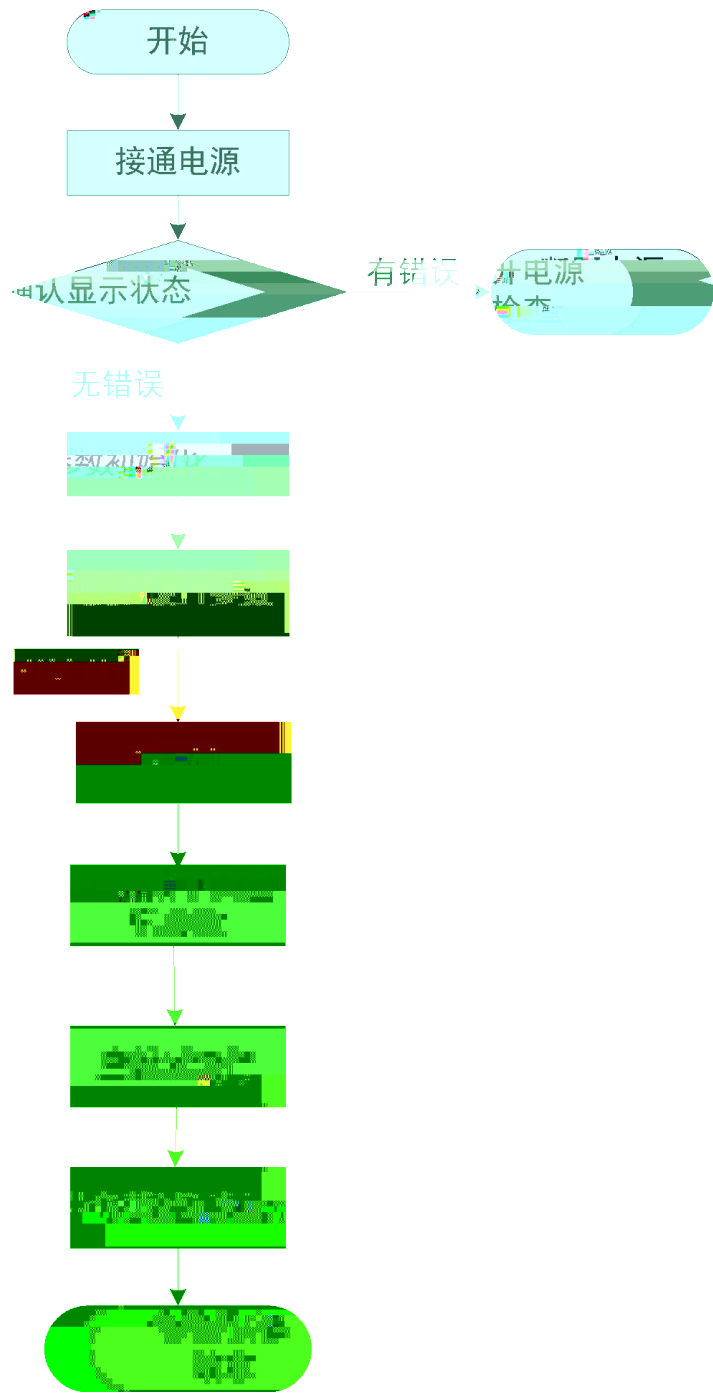

---

---



---

---

---

	FO

F > |



ö 7

j \ 7 0 ~

---

---







---

---

---





---

--	--	--	--	--

---

---





---



---





---









---

---



---

---

---

**GUIDE**

---

























---



---











---

---



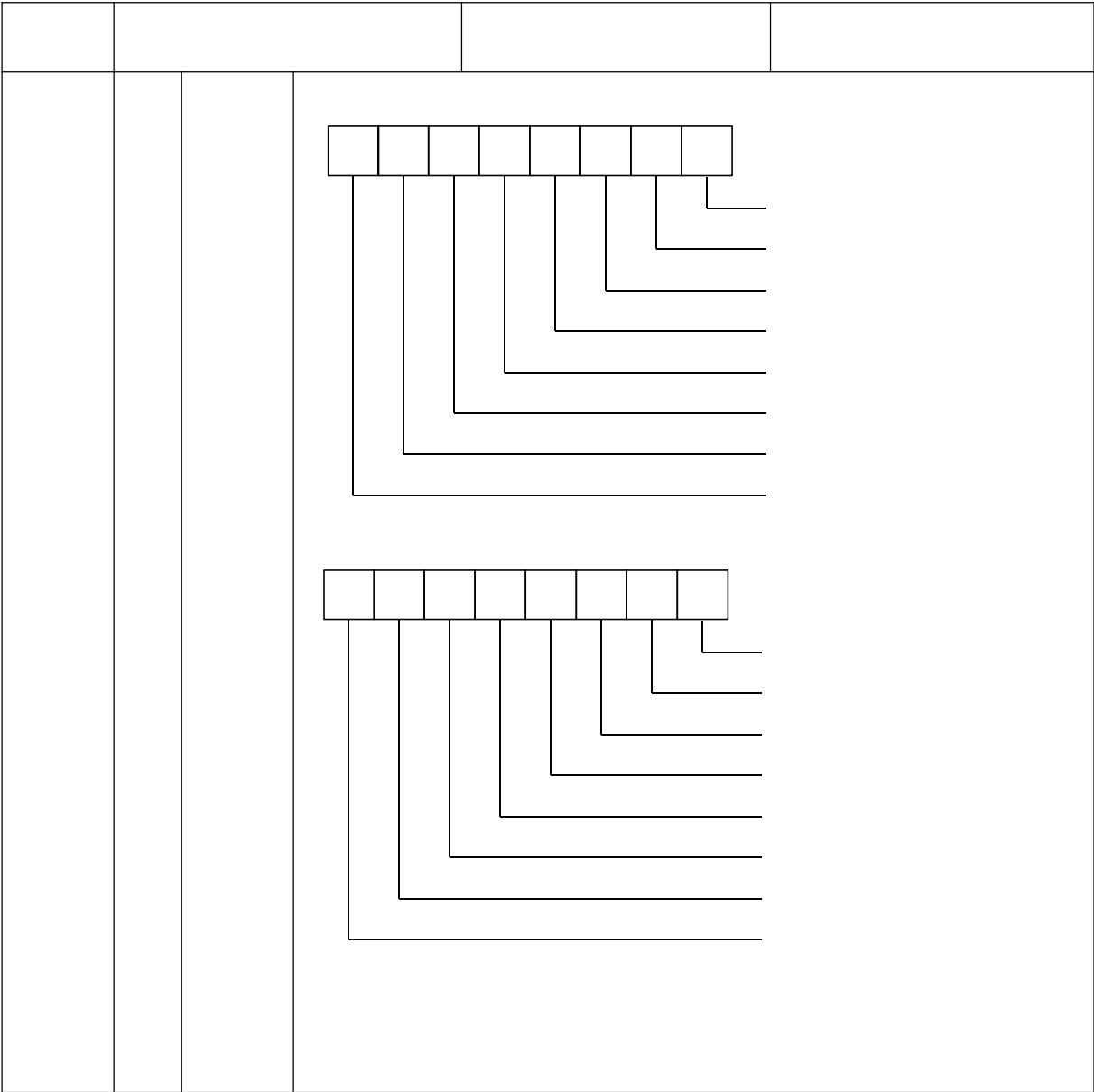



---

---







---

---

---









**GUIDE**

---



--	--	--	--

---

21

D u12

E4E- 0

E4E

---

---



---



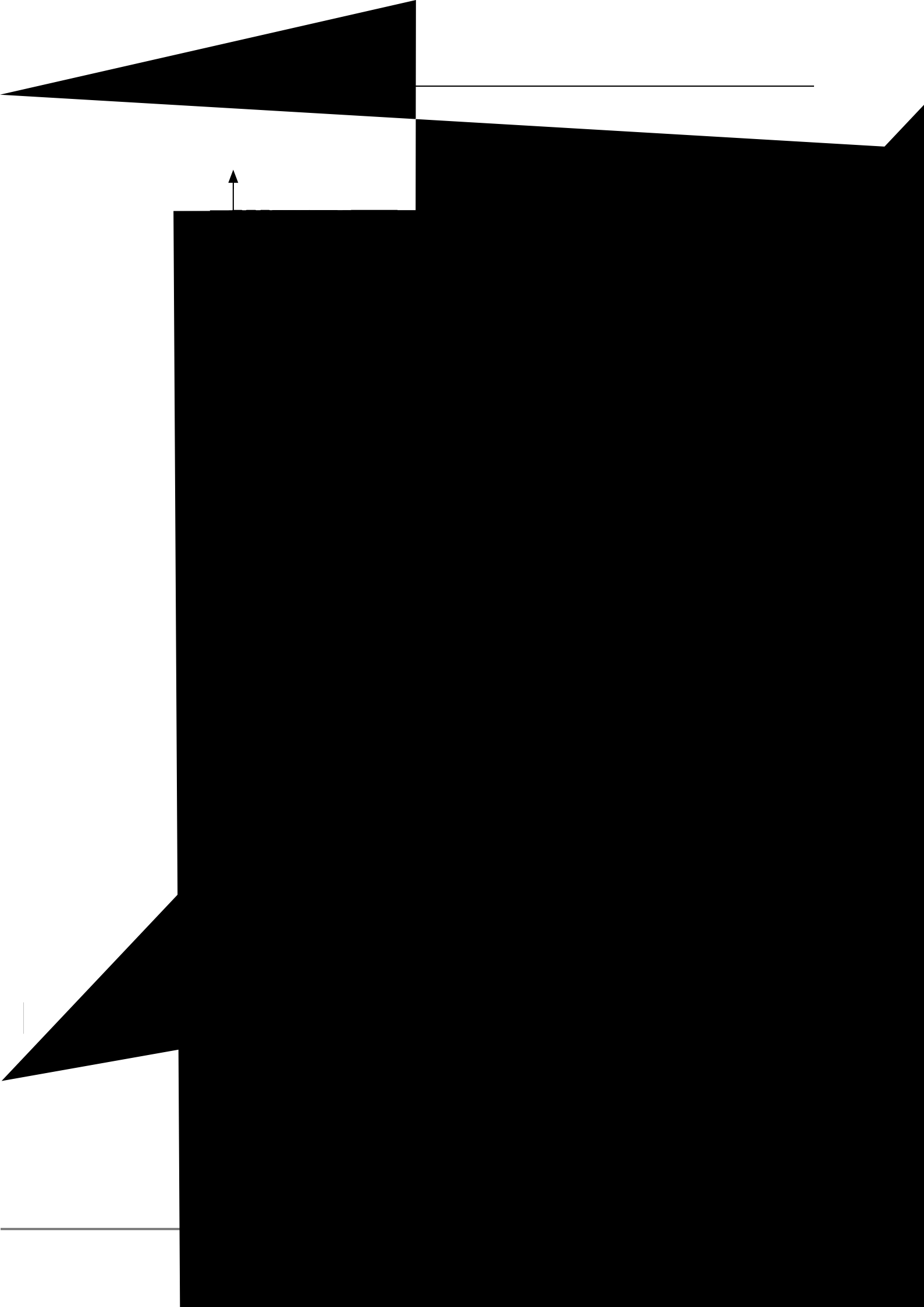

---



---

---

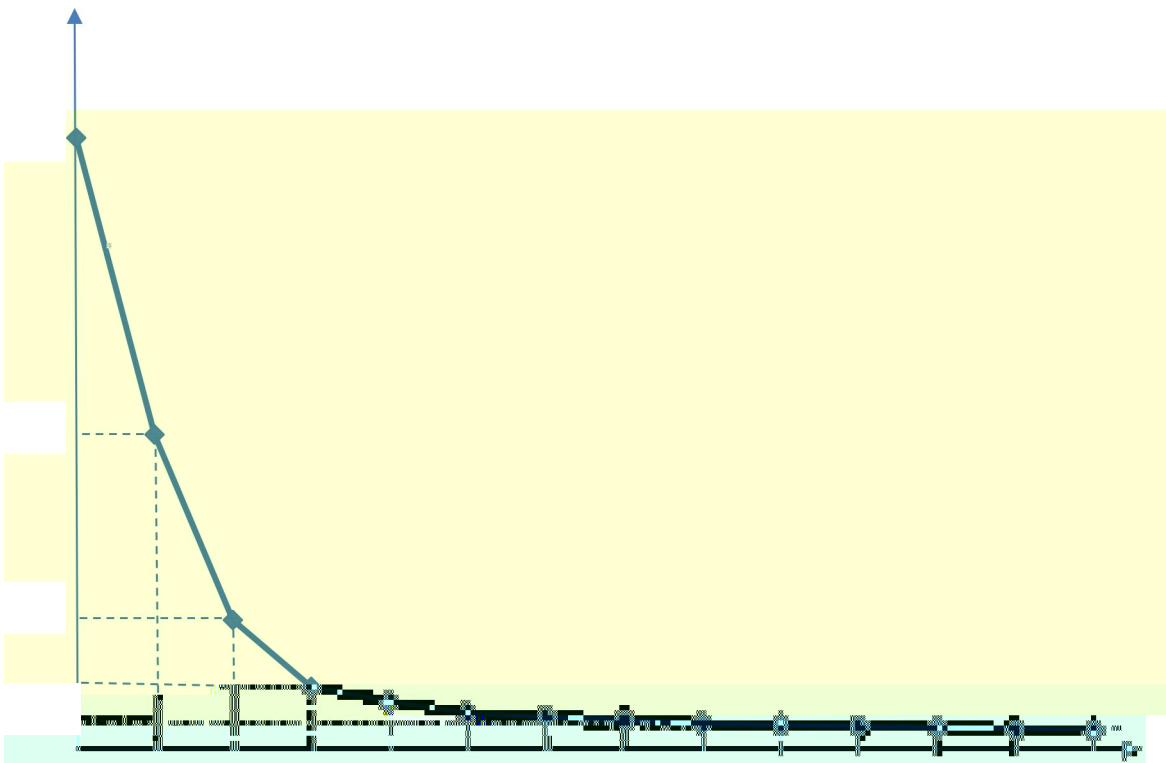



---





Ö

Ä 3

Efús at 0 E- 44 È DIEMBAALIO 0 ~

输出电流 ▲



8 Ø			

2

		+e_C§	

---









---



---



---





/y

© 2010 by [unreadable]

K^ .° p

© 2010 R )

©, @ñ0 R ) , @ñ0 TH''%sK^P'GpE

Aí 90-509 Ñ,`





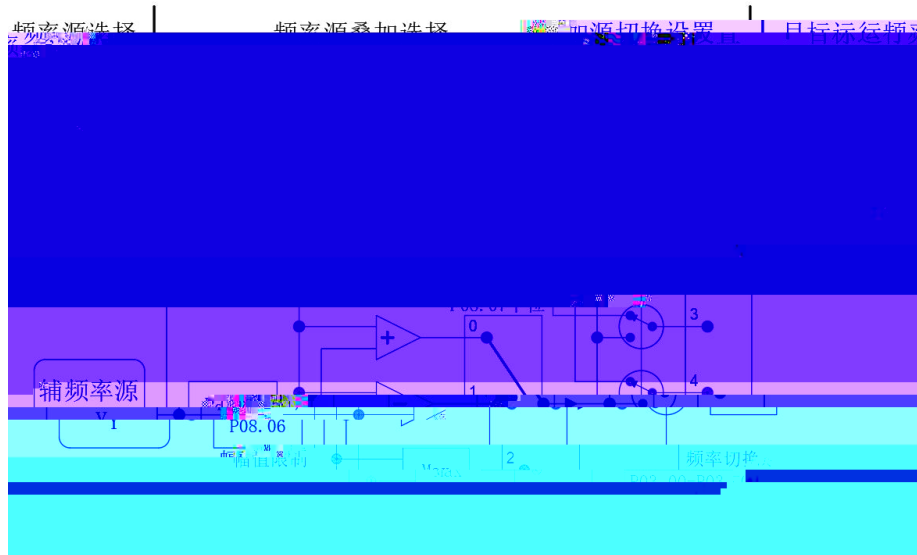

---

--	--	--	--

---





---



---

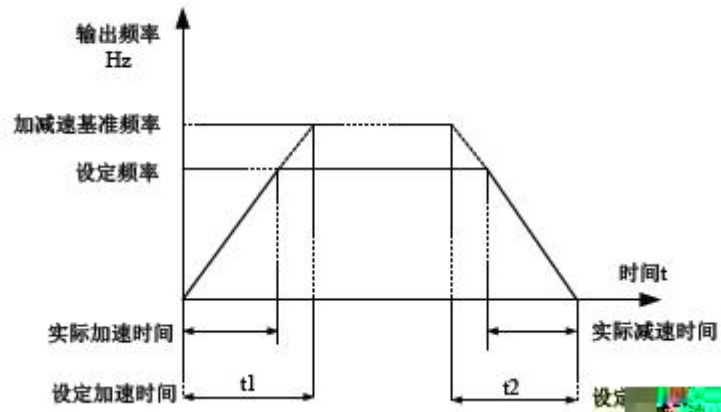

---



---









---

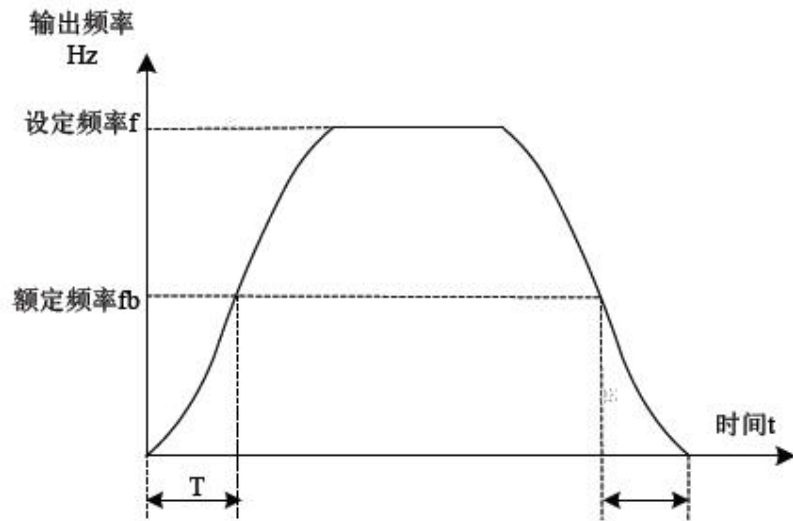

---

$$t = \left( \frac{4}{9} \times \left( \frac{f}{f_b} \right)^2 + \frac{1}{9} \right) \times T$$







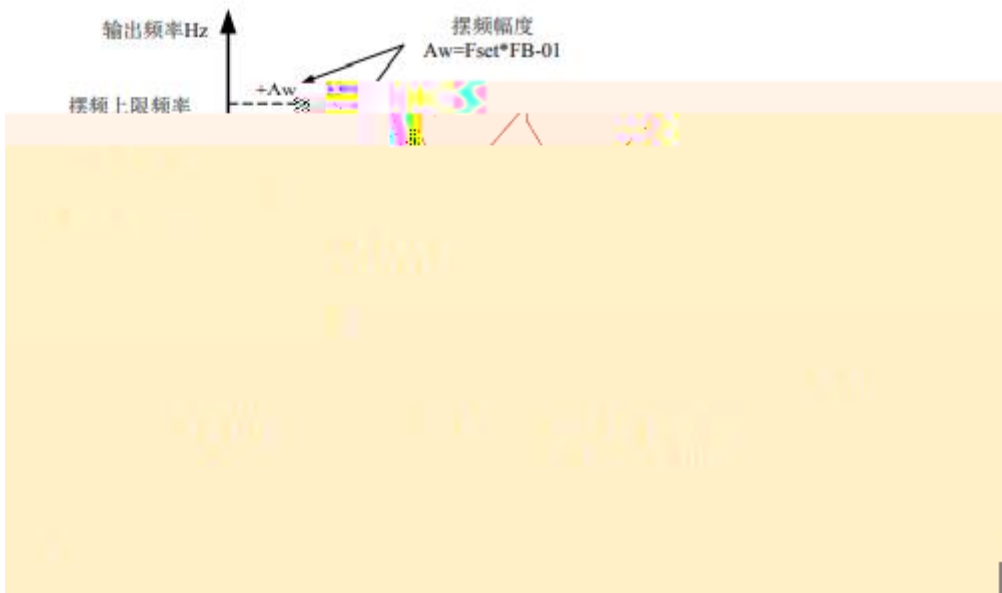



---



---

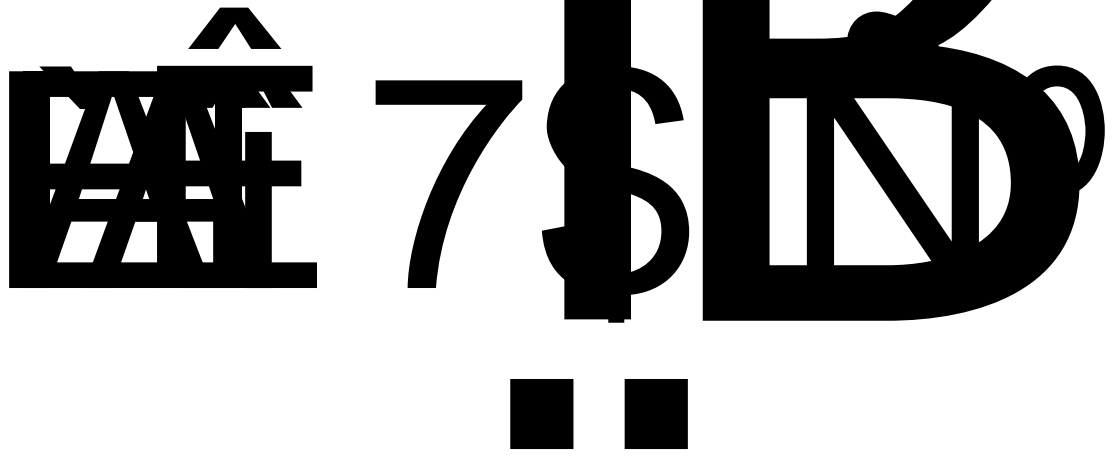





---



---



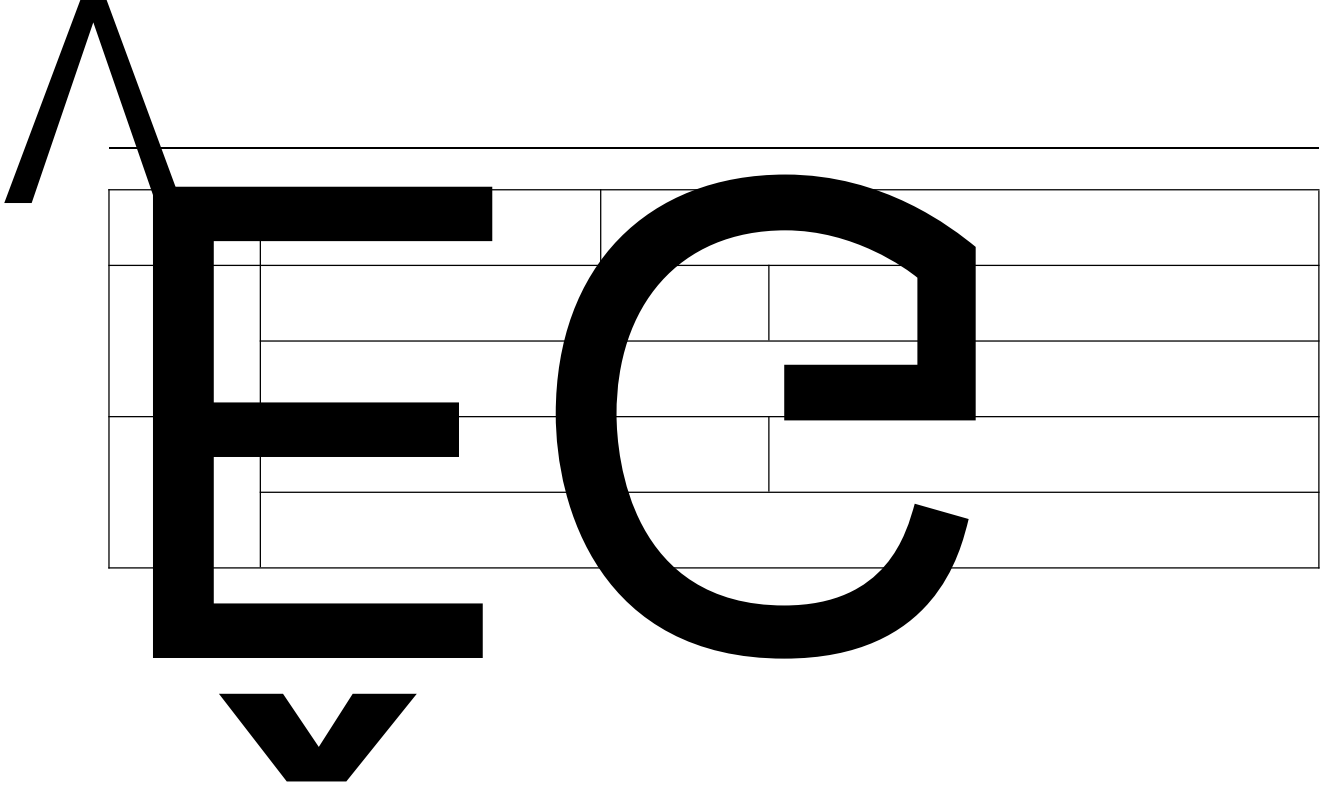



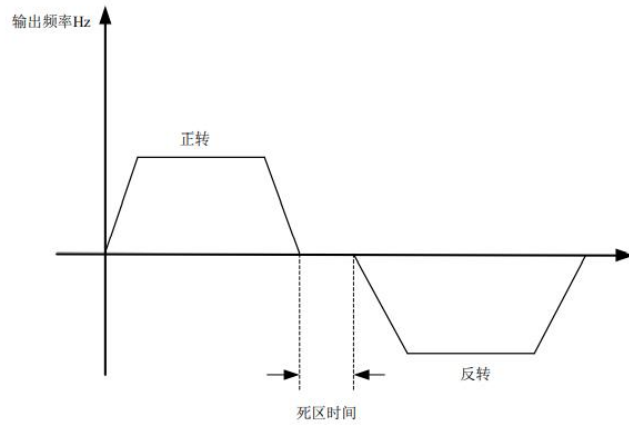

**GUIDE**

---

---

---



---

---

---

---

---

---

---

---

---

---

---

---

---

---

\* ^A•é l

---







---



---

8.8.8.8		

---









GDGF630N01-4+SW01 V2-DOC-UM-REV1.00

2026.02